

# Some aspects of integration of renewable sources in the North American grid: experiences, problems and trends

Aleksandar M Stankovic

Alwin H Howell Professor  
Department of Electrical and Computer Engineering  
Tufts University, Medford, MA

June 2019



# Outline

- 1 Issues with Energy Systems
- 2 Electric Energy Today
  - Why Systems?
  - Multilayer Structure
- 3 A Brief Overview of Renewables
  - Variability and Uncertainty
  - US Electricity Markets
- 4 Emerging and Future Systems
  - Some Leads on Integration
  - US East Coast



# Energy is Everywhere

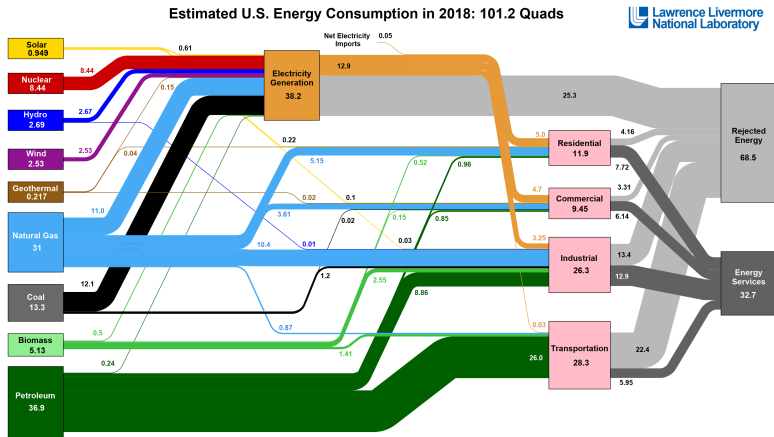

Sources: EIA, March, 2019. Data is based on DOE/EIA MERA (2019). If this information or a reproduction of it is used, credit must be given to the Lawrence Livermore National Laboratory and the Department of Energy, under whose auspices the work was performed. Distributed electricity represents only retail electricity sales and does not include self-generation. EIA reports consumption of renewable resources (i.e., hydro, wind, geothermal, and solar) for electricity in BTU-equivalent values by assigning a typical fossil fuel plant heat rate. The efficiency of electricity production is calculated as the total retail electricity delivered divided by the primary energy input into electricity generation. End use efficiency is estimated as 65% for the residential sector, 68% for the commercial sector, 25% for the transportation sector and 62% for the industrial sector, which was updated in 2017 to reflect DOE's analysis of manufacturing. Totals may not equal sum of components due to independent rounding. LLNL-MI-110371



# Not Very Different

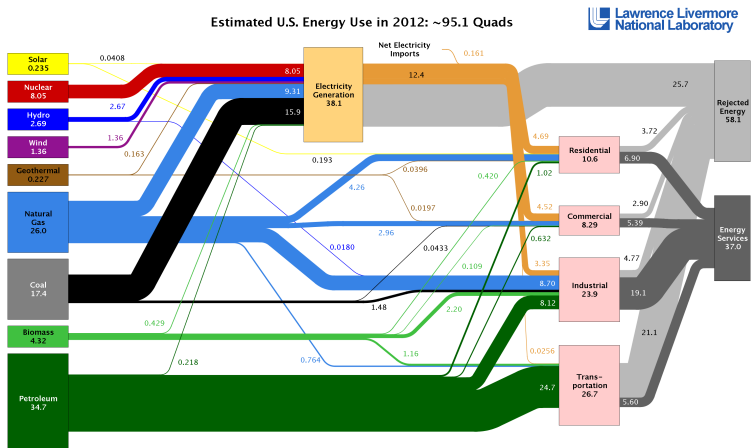

Source: LLNL 2013. Data is based on DOE/EIA-0035(2013-05), May, 2013. If this information or a reproduction of it is used, credit must be given to the Lawrence Livermore National Laboratory and the Department of Energy, under whose auspices the work was performed. Distributed electricity represents only retail electricity sales and does not include self-generation. EIA reports consumption of renewable resources (i.e., hydro, wind, geothermal and solar) for electricity in BTU-equivalent values by assuming a typical fossil fuel plant "heat rate." The efficiency of electricity production is calculated as the total retail electricity delivered divided by the primary energy input into electricity generation. End use efficiency is estimated as 65% for the residential and commercial sectors 80% for the industrial sector, and 21% for the transportation sector. Totals may not equal sum of components due to independent rounding. LLNL-MI-110527



# Some Major Connections

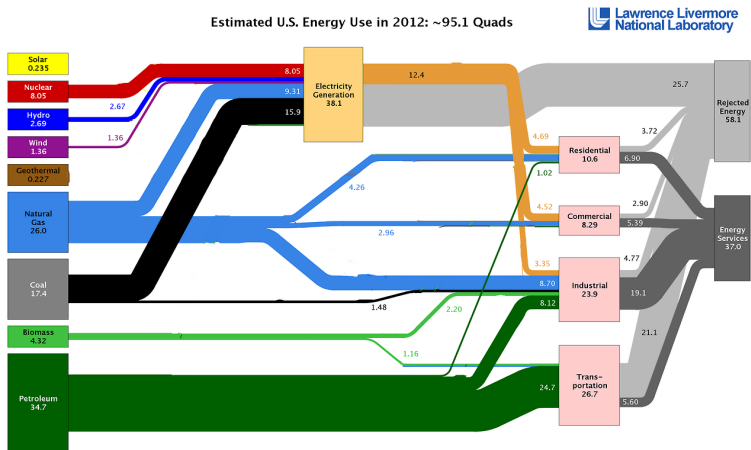

Source: LLNL 2013. Data is based on DOE/EIA-0093(2013-05), May, 2013. If this information or a reproduction of it is used, credit must be given to the Lawrence Livermore National Laboratory and the Department of Energy, under whose auspices the work was performed. Distributed electricity represents only retail electricity sales and does not include self-generation. EIA reports consumption of renewable resources (i.e., hydro, wind, geothermal and solar) for electricity in BTU-equivalent values by assuming a typical fossil fuel plant "heat rate." The efficiency of electricity production is calculated as the total retail electricity delivered divided by the primary energy input into electricity generation. End use efficiency is estimated as 65% for the residential and commercial sectors 80% for the industrial sector, and 21% for the transportation sector. Totals may not equal sum of components due to independent rounding. LLNL-MI-110527



# And really not very different...

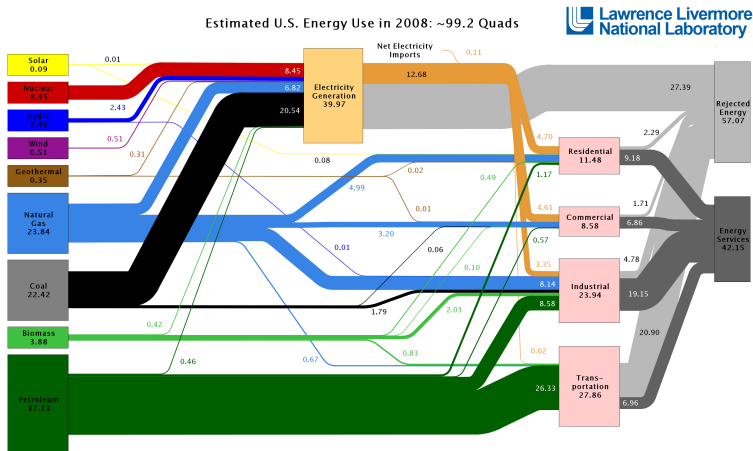

Source: LLNL, 2009. Data is based on DOE/EIA-0384(2008), June 2009. If this information or a reproduction of it is used, credit must be given to the Lawrence Livermore National Laboratory and the Department of Energy, under whose auspices the work was performed. Distributed electricity represents only retail electricity sales and does not include self-generation. EIA reports flows for non-thermal resources (i.e., hydro, wind and solar) in BTU-equivalent values by assuming a typical fossil fuel plant "heat rate." The efficiency of electricity production is calculated as the total retail electricity delivered divided by the primary energy input into electricity generation. End use efficiency is estimated as 80% for the residential, commercial and industrial sectors, and as 25% for the transportation sector. Totals may not equal sum of components due to independent rounding. LLNL-410527



# Mostly From Fossil Fuels



# Some consequences...

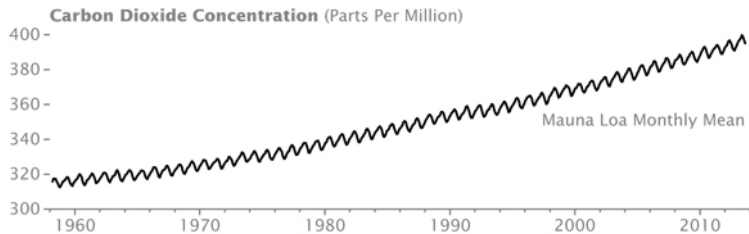

# Some Concurrent Events

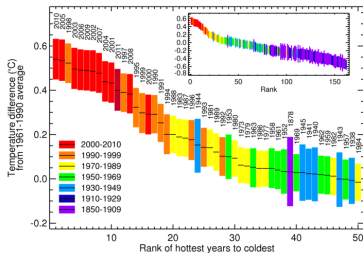
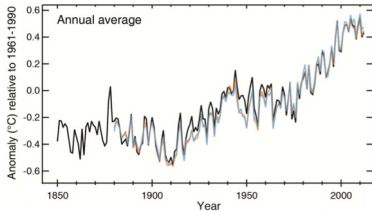

# Reliability

## System Solution

Systems aim to achieve level of **reliability** that far exceeds that of individual components through control actions.

## Targets

Reliability %	N "nines"	Down time
99.9	3	9 hr/yr
99.999	5	5 min/yr
99.99999	7	3 sec/yr
99.9999999	9	2 cycles/yr



# Reliability

## System Solution

Systems aim to achieve level of **reliability** that far exceeds that of individual components through control actions.

## Targets

Reliability %	N "nines"	Down time
99.9	3	9 hr/yr
99.999	5	5 min/yr
99.99999	7	3 sec/yr
99.9999999	9	2 cycles/yr



# Performance

## Specifications

Utility systems

$N=4-5$





Server farms

$N=7-8$



# Somewhat Comparable Events

## From Everyday Life

Losing in roulette	$N=1.6$	
Flight without fatality	$N=7$	
Losing the PowerBall lottery	$N=8$	

# When Systems Fail...

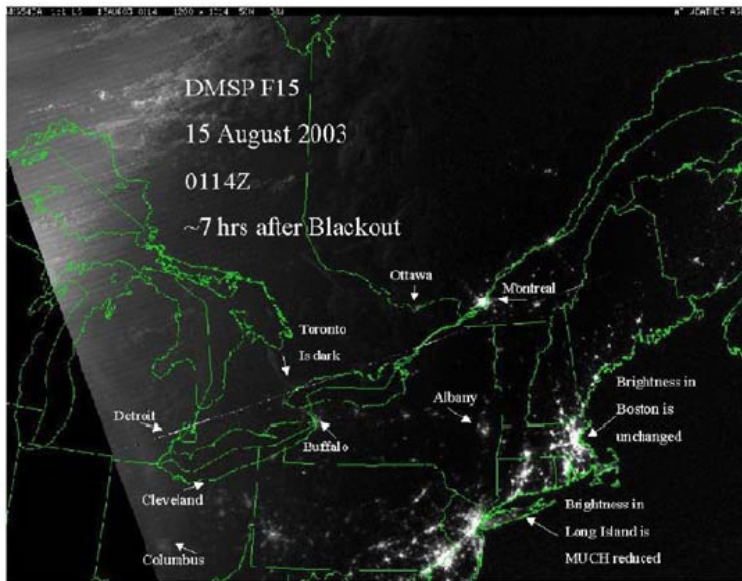

# Multilayer structure

## Infrastructure systems

Four main layers - **matter**, **energy**, **information** and **capital** flows.

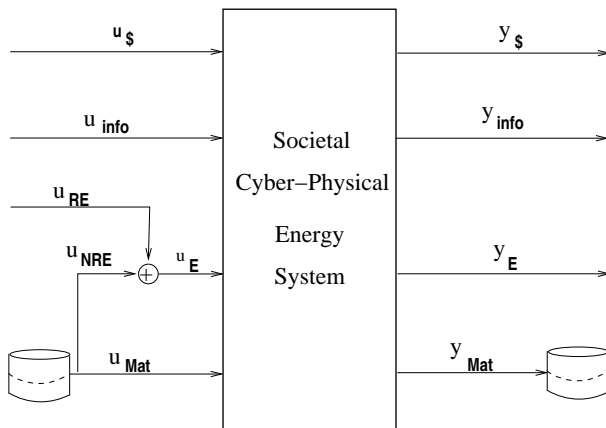

# Metrics for Energy Systems

- Resilience - reliability **and** active adversaries (across layers),
- Efficiency - normal operation (energy layer),
- Security (information layer),
- Affordability (capital layer),
- Sustainability (material flow layer).



## Multiscale and hybrid

- In time - 10 orders of magnitude
- In space - 7 orders of magnitude
- By power - 10 orders of magnitude



## Design

Built for **efficiency**.

## Uncertain

- **Normal** and **faulted** operation - nature and active adversaries,
- Uncertain inputs, regularized by physics,
- Sparse sensing and intelligence at the periphery.

## Multiscale and hybrid

- In time - 10 orders of magnitude
- In space - 7 orders of magnitude
- By power - 10 orders of magnitude



## Design

Built for **efficiency**.

## Uncertain

- Normal and faulted operation - nature and active adversaries,
- Uncertain inputs, regularized by physics,
- Sparse sensing and intelligence at the periphery.

## Multiscale and hybrid

- In time - 10 orders of magnitude
- In space - 7 orders of magnitude
- By power - 10 orders of magnitude



## Design

Built for **efficiency**.

## Uncertain

- **Normal** and **faulted** operation - nature and active adversaries,
- Uncertain inputs, regularized by physics,
- Sparse sensing and intelligence at the periphery.

# Existing Electric Energy Systems

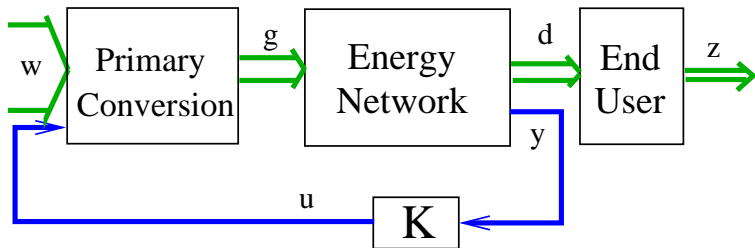

- $w$  too large, **little** from **renewables**,
- **Unable** to integrate novel components,
- Non-functional **markets**,
- **Over-designed components** - variations in  $z$ ,
- **Over-designed components** - **fault** accommodation,
- **Cascading** faults.



# Existing Electric Energy Systems

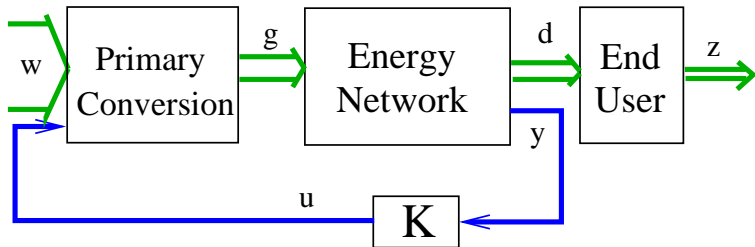

- $w$  too large, **little** from **renewables**,
- **Unable** to integrate novel components,
- Non-functional **markets**,
- **Over-designed components** - variations in  $z$ ,
- Over-designed components - **fault** accommodation,
- **Cascading** faults.



# Resilience - a definition

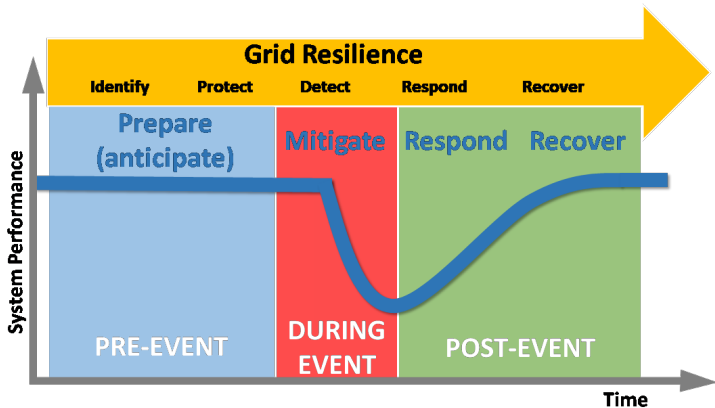

The ability to prepare for and adapt to changing conditions and withstand and recover rapidly from disruptions.



# Reliability and Resilience

## Reliability:

- Operating reliability is the ability of the electric system to withstand sudden disturbances such as electric short circuits or unanticipated loss of system components
- Today, reliability refers to high-probability, relatively low-impact events (for which power systems have been traditionally designed and operated for).

## Resilience:

- Resilience addresses low-probability, high-impact events,
- Scenario-based, shorter time-frame, time-variability, quantification of interventions.



# Reliability and Resilience

## Reliability:

- Operating reliability is the ability of the electric system to withstand sudden disturbances such as electric short circuits or unanticipated loss of system components
- Today, reliability refers to high-probability, relatively low-impact events (for which power systems have been traditionally designed and operated for).

## Resilience:

- Resilience addresses low-probability, high-impact events,
- Scenario-based, shorter time-frame, time-variability, quantification of interventions.



# A recent high-impact event

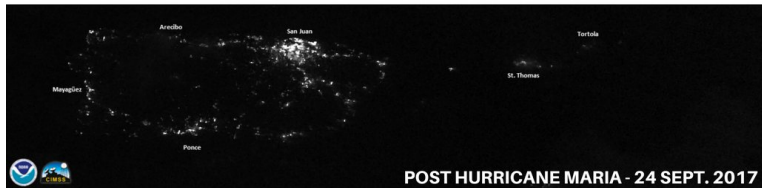
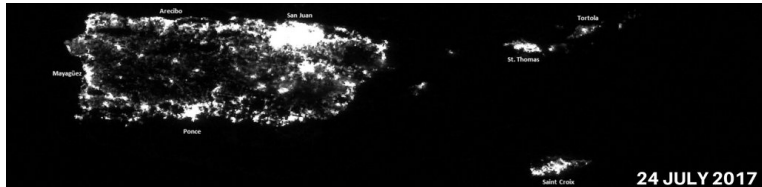

# Wind variability over days

**E-ON wind power variation over the year (theoretical max : 7.558 MW)**

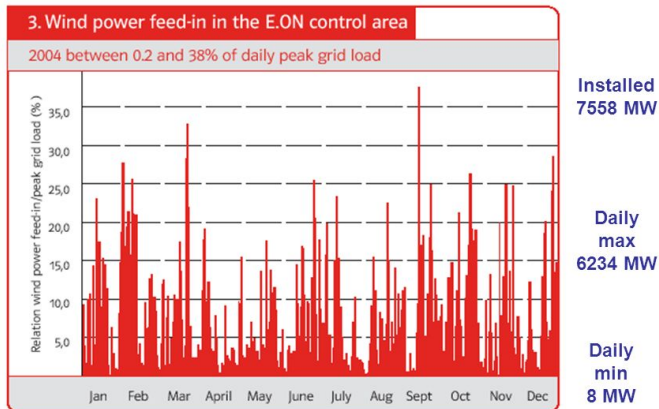

Installed capacity: 33.200MW including wind 7.558 MW (23%)

Production: 271.300 MWh incl. wind 11.300 MWh (4,16%)



# And over hours

## Delivered wind power: details of variation per 15 min

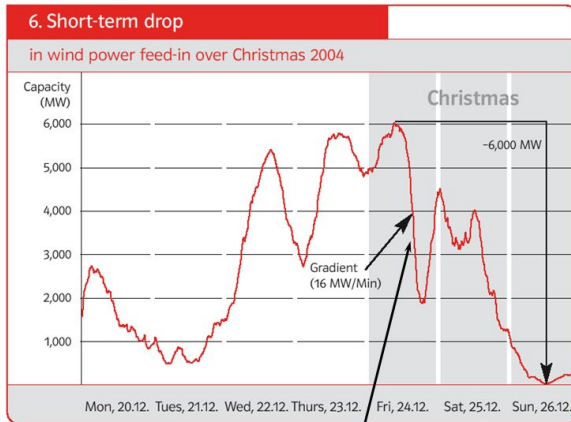

**Gradient: 1000 MW/h**



# Combined Renewables are No Different

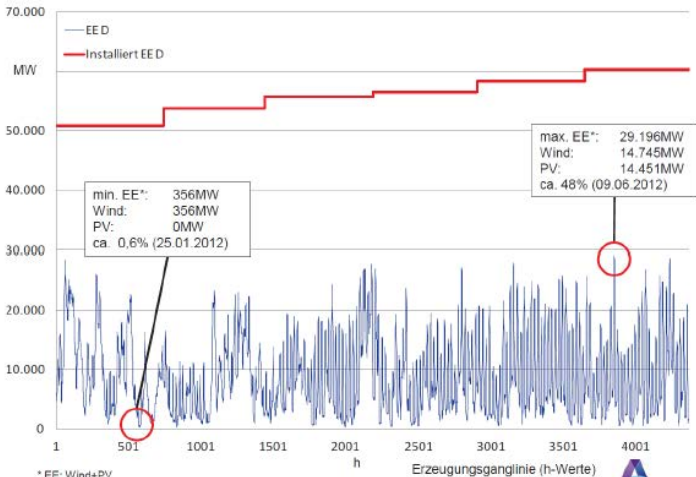

Systemführung Netze Brauweiler | Betriebliche Erfahrungen mit der Energiewende | © Amprion



# Prediction is limited

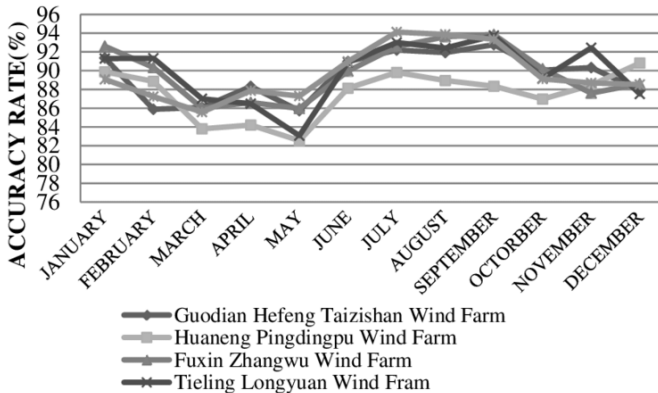

# Prices are a Half of European

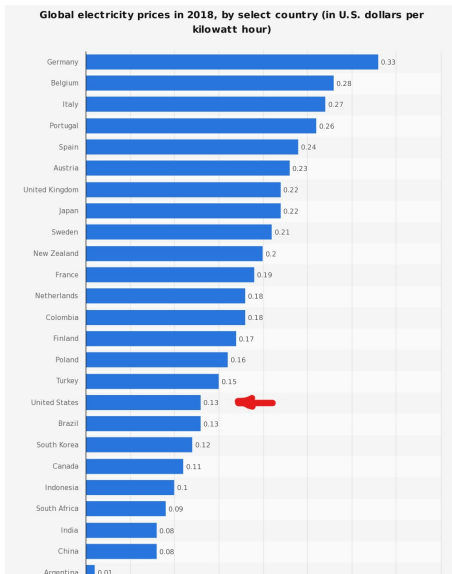

# Competing Sources

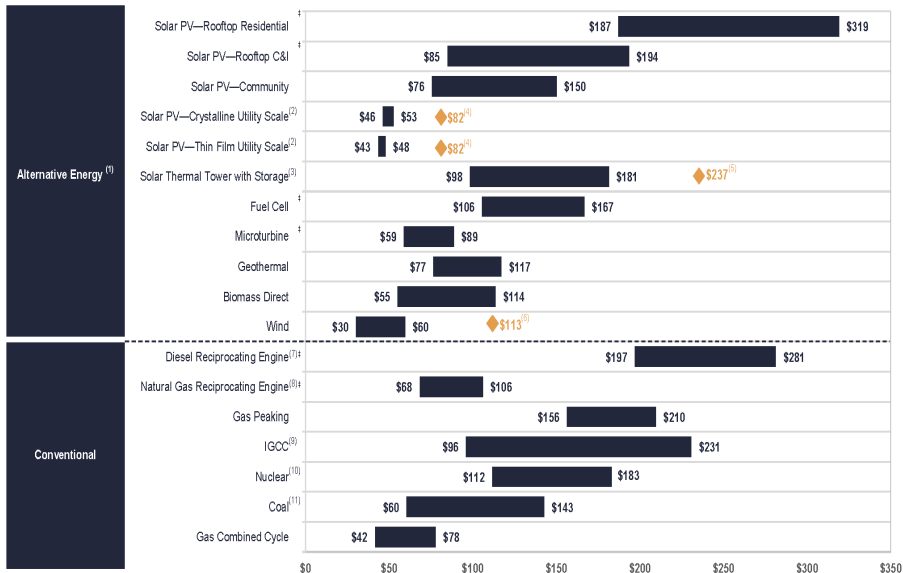

# And Governmental Influences...

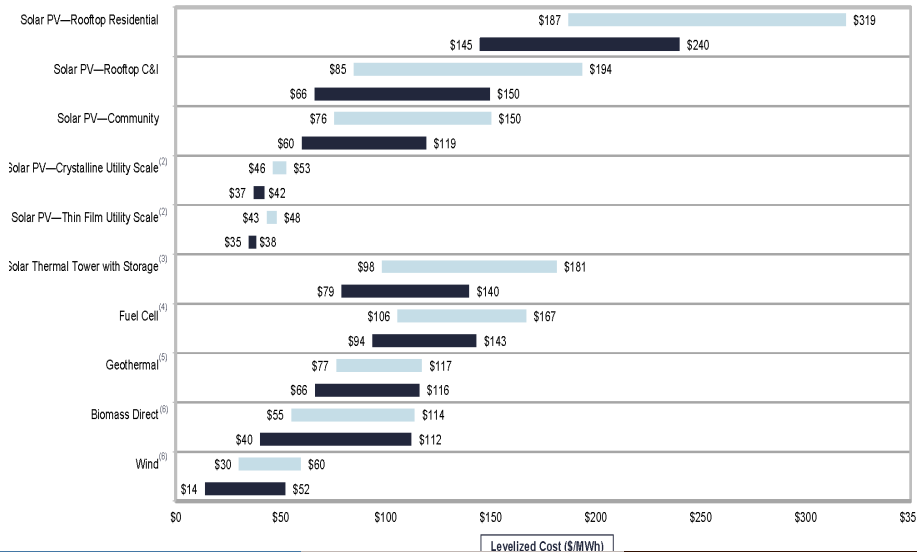

# An Example - CAISO Duck

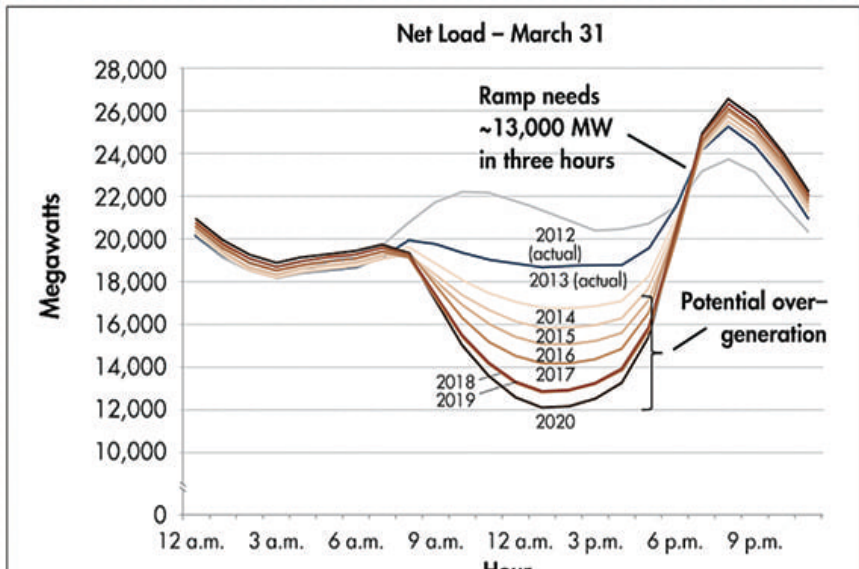

# Approaches to Integration of Renewables

## Approach

Source-following ethos (→ more grid).

## Coordination

- Larger spatial areas, dynamically varied,
- Hybrid systems with conventional sources, and
- Flexibility - better forecasts, dispatchable loads, buy / sell algorithms, storage.

## Integration into larger structures

- Transmission / distribution integration,
- Multiple energy carriers (H2 - HENG),
- Energy hubs - various forms of storage.



# Approaches to Integration of Renewables

## Approach

Source-following ethos (→ more grid).

## Coordination

- Larger spatial areas, dynamically varied,
- Hybrid systems with conventional sources, and
- Flexibility - better forecasts, dispatchable loads, buy / sell algorithms, storage.

## Integration into larger structures

- Transmission / distribution integration,
- Multiple energy carriers (H2 - HENG),
- Energy hubs - various forms of storage.



# Approaches to Integration of Renewables

## Approach

Source-following ethos (→ more grid).

## Coordination

- Larger spatial areas, dynamically varied,
- Hybrid systems with conventional sources, and
- Flexibility - better forecasts, dispatchable loads, buy / sell algorithms, storage.

## Integration into larger structures

- Transmission / distribution integration,
- Multiple energy carriers (H2 - HENG),
- Energy hubs - various forms of storage.



# Future Electric Energy Systems

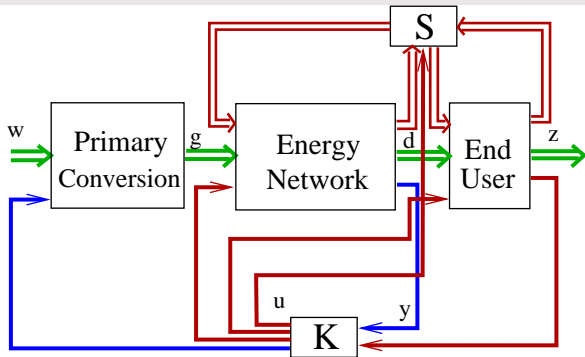

- **Information layer** (sensors, coordinated  $K$  = local + global context, loads inside)
- **Better** blocks,
- More  $w$  from **renewables**,
- **Flatter** control - decoupling from above and below, faster, more storage and routing,
- Better **design** while steering component development.



# Future Electric Energy Systems

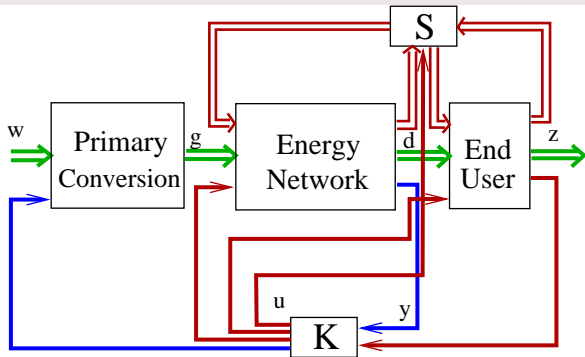

- **Information layer** (sensors, coordinated  $K$  = local + global context, loads inside)
- **Better** blocks,
- More  $w$  from **renewables**,
- **Flatter** control - decoupling from above and below, faster, more storage and routing,
- Better **design** while steering component development.



# Smart Grid

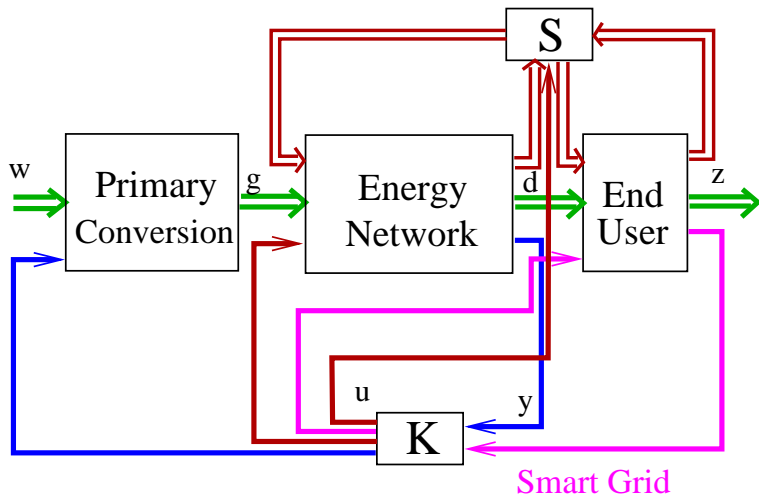

# Scales in Space and Time

## Multi-Scale: Time, Space, Power

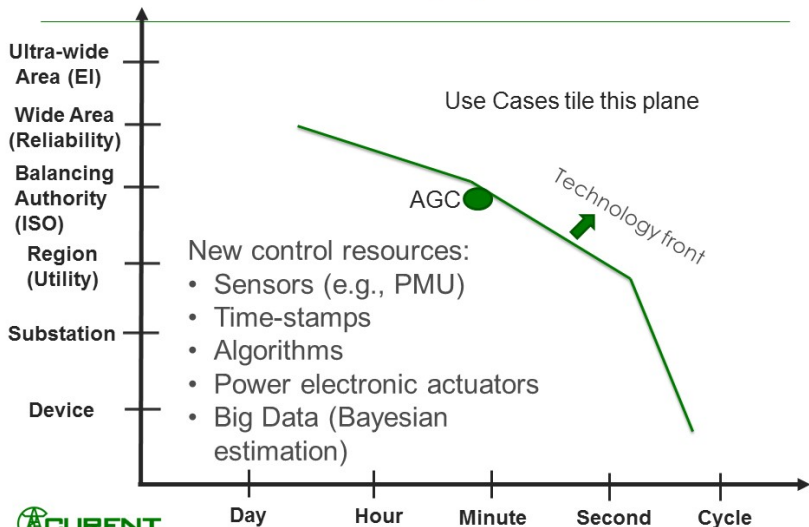

# Interconnected Energy

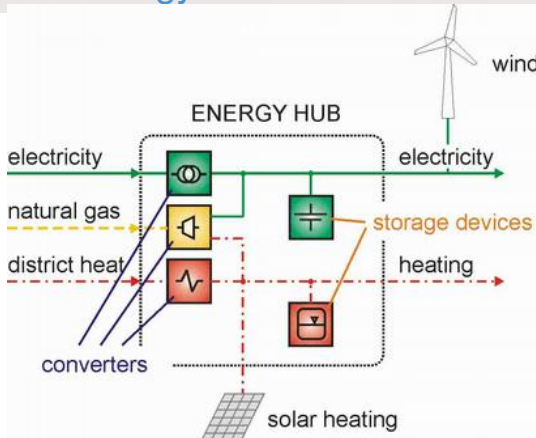

## Networked multi-carrier energy hubs

By connecting and coordinating different single-carrier systems in societal cyber-physical networks overall performance can be dramatically improved.

# Full Disclosure...



# Geography

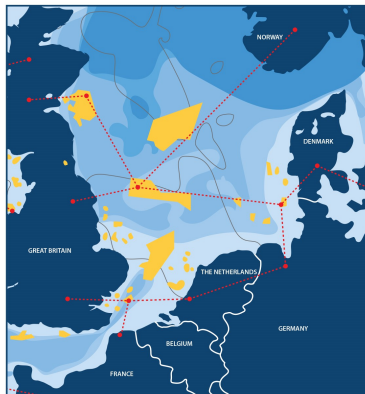
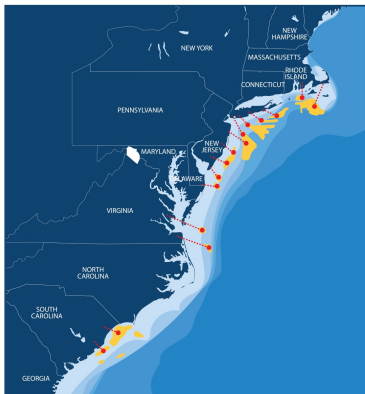

# Issues

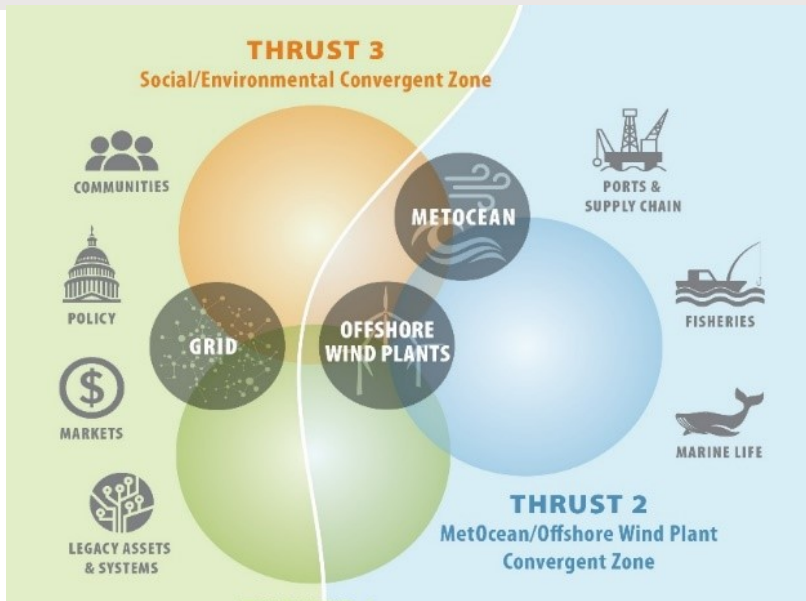

# A Massive Infrastructure

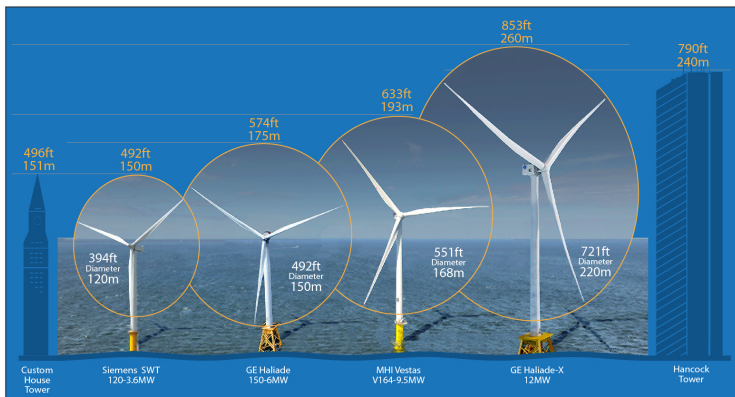

# Challenging Environment - Resilience Matters!



# Policy Matters



# Motivation for Change Persists



GEORF ROBINSON PHOTOGRAPHY/REDAWUTTERSTOCK



# Summary

## Societal Expectations

- carbon-free electricity,
- efficient and resilient networks,
- functional markets and public policy.

## Transition Path

- The efficiency is determined by the energy flow layer,
- **Key enablers** for improvement are in the information flow layer,
- The trajectory will be driven by the material and capital flow layers.



# Summary

## Societal Expectations

- carbon-free electricity,
- efficient and resilient networks,
- functional markets and public policy.

## Transition Path

- The efficiency is determined by the energy flow layer,
- **Key enablers** for improvement are in the information flow layer,
- The trajectory will be driven by the material and capital flow layers.



# Electricity Efficiencies

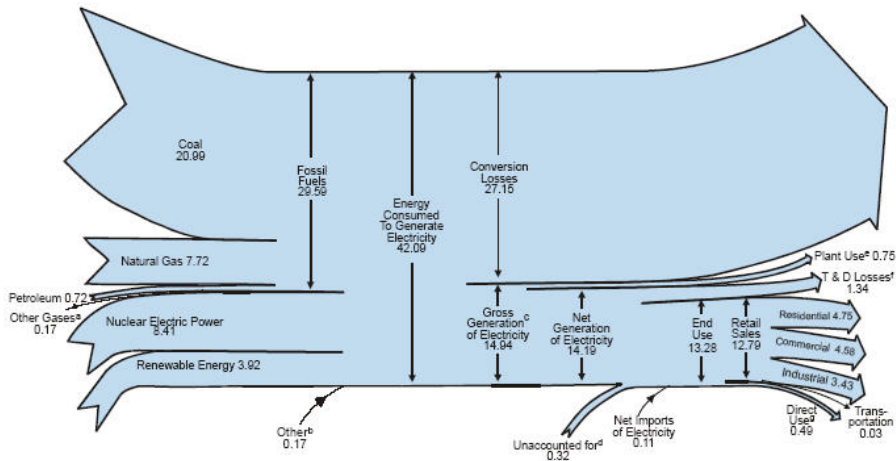

## A Similar Plot...

